



NJBK5 Motor Controller

1. General

NJBK5 series motor controller (hereinafter referred to as controller) is mainly used in circuits with a frequency of AC 50Hz (or 60Hz), a rated operational voltage of up to 380V and a rated control power of up to 11kW (current up to 22A) to control the direct start and stop of water pumps or motors, provide motors with overload and phase failure protection, and realize automatic liquid level control for civil water towers and reservoirs.

This product is not applicable to the liquid level control of low-conductivity liquids, such as oil, purified water, inflammable and explosive chemical liquids and high-density sewage.

Standards: IEC 60947-4-1.

2. Type designation

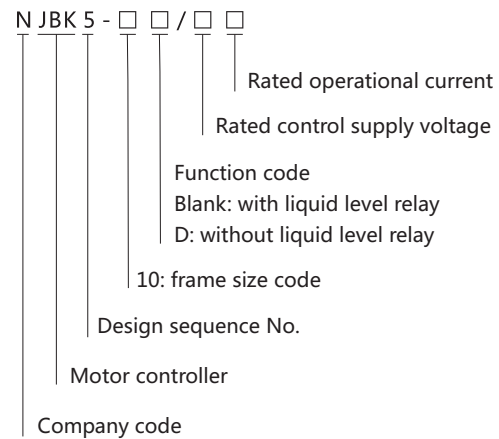

3. Operating conditions

- 3.1 Altitude: the altitude of the mounting location should not exceed 2000m;
- 3.2 Ambient temperature: $-5^{\circ}\text{C}\sim+40^{\circ}\text{C}$, and the average temperature in 24h should not exceed $+35^{\circ}\text{C}$;
- 3.3 Atmospheric conditions: The relative air humidity at the mounting location should not exceed 50% at the maximum temperature of $+40^{\circ}\text{C}$. The relative humidity may be higher at lower temperatures. Special measures should be taken if condensation occurs on the product occasionally due to temperature variation;
- 3.4 Pollution degree: 3;
- 3.5 Mounting category: III;
- 3.6 In places where there is no significant vibration or impact;
- 3.7 In non-explosive media that do not contain a sufficient amount of gas or dust to cause metal corrosion or insulation failure;
- 3.8 In places where rain and snow protection is provided;
- 3.9 The inclination from the vertical plane should not exceed 5° .

4 Technical data

4.1 Main data and technical characteristics

Type	Conventional heating current (A)	Max. rated power (kW)		Model of matching AC contactor	Model of matching motor protector	Setting current range (A)	Number of turns of protector (turn)
		AC-3					
		380V	220V				
NJBK5-10 0.72A~2.4A	2.4	1.1	0.55	NXC-06/CJX2-1210	JD-8/0.5A~5A	0.72~2.4	5
NJBK5-10D 0.72A~2.4A							
NJBK5-10 3.5A~11A	12	5.5	3	NXC-12/CJX2-1210	JD-8/2A~20A	3.5~11	1
NJBK5-10D 3.5A~11A							
NJBK5-10 10A~16A	16	7.5	4	NXC-16/CJX2-1810	JD-8/2A~20A	10~16	1
NJBK5-10D 10A~16A							
NJBK5-10 20A~25A	25	11	5.5	NXC-25/CJX2-2510	JD-8/20A~80A	20~25	1
NJBK5-10D 20A~25A							

4.2 Rated control supply voltage U_s : AC220V, AC380V.

4.3 Degree of protection of enclosure: IP55.

4.4 Protection characteristics of the controller

4.4.1 Phase failure protection characteristics of the controller: In case of failure of any phase of the three-phase main circuit passing through the center hole of the motor comprehensive protector in the controller, the motor comprehensive protector operates for a period of $\leq 5s$.

4.4.2 Overload protection characteristics of the controller under balanced three-phase load.

No.	Setting current multiple	Operation time			Starting conditions
1	1.05	No operation within 2h			Cold state start
2	1.2	Operation within 2h			Start after No.1
3	1.5	Tripping class	30	$\leq 12min$	Start after applying a 1.0 times setting current for 2h
4	7.2	Tripping class	30	$9s < T_p \leq 30s$	Cold state start

4.5 Down-lead distance of liquid level control electrode: 200m max.

4.6 Mounting type: installation type.

5. Features

The controller consists of a NXC or CJX2 series AC contactor, a JD-8 series motor comprehensive protector and an NJB1-YW1 liquid level relay in a protective enclosure and is divided into two types, with liquid level relay and without liquid level relay. Products with liquid level relay are used to control the start and stop and automatic pumping and drainage of water pumps and provide overload and phase failure protection. Products without liquid level relay are used to control the start and stop of motors and provide overload and phase failure protection.

Setting of the motor comprehensive protector in the controller is required before it is connected and put into use.

6. Wiring diagram

a. Connection diagram of NJBK5-10 in case both the control circuit voltage and the main circuit voltage are AC380V

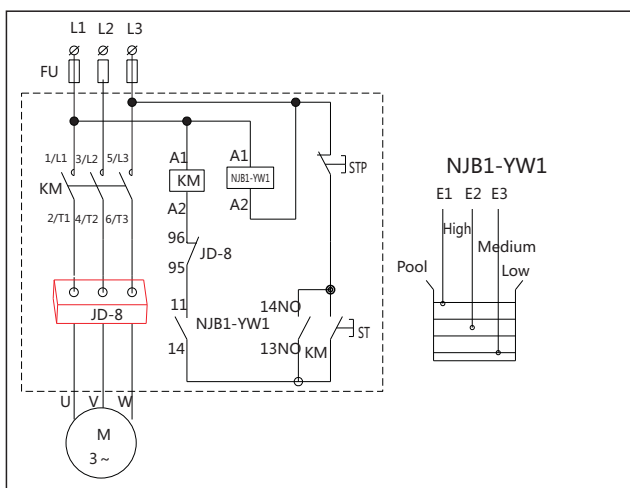

b. Connection diagram of NJBK5-10 in case the main circuit voltage is AC380V and the control circuit voltage is AC220V

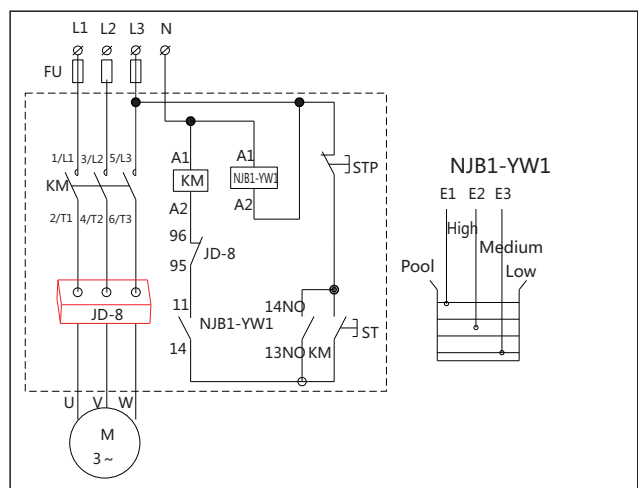

a. Connection diagram of NJBK5-10D in case both the control circuit voltage and the main circuit voltage are AC380V

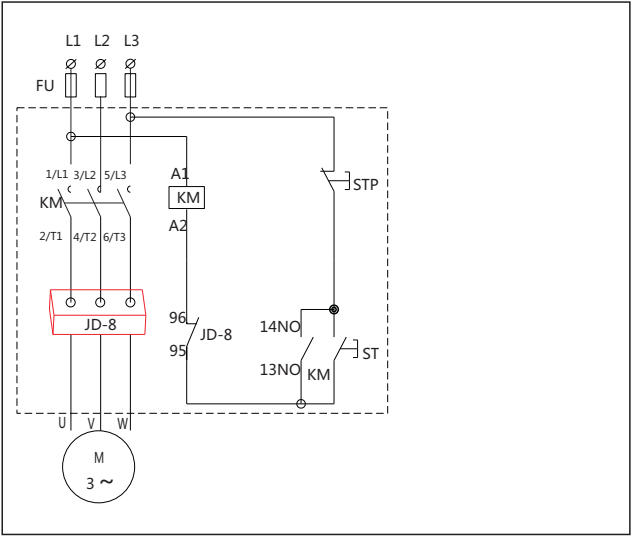

b. Connection diagram of NJBK5-10D in case the main circuit voltage is AC380V and the control circuit voltage is AC220V

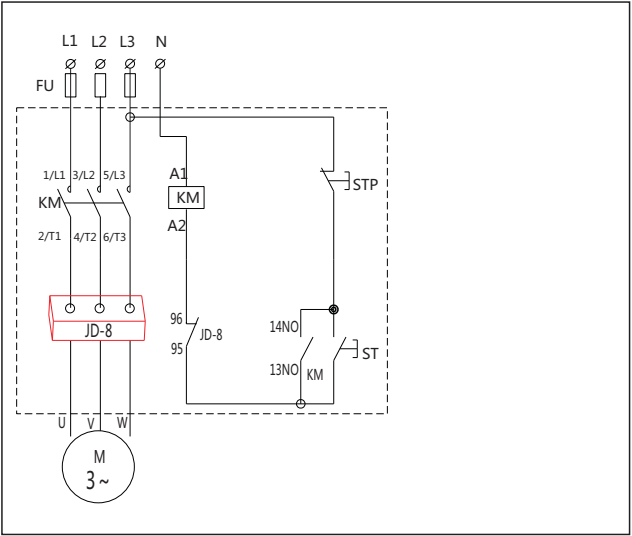

7. Overall and mounting dimensions (mm)

